

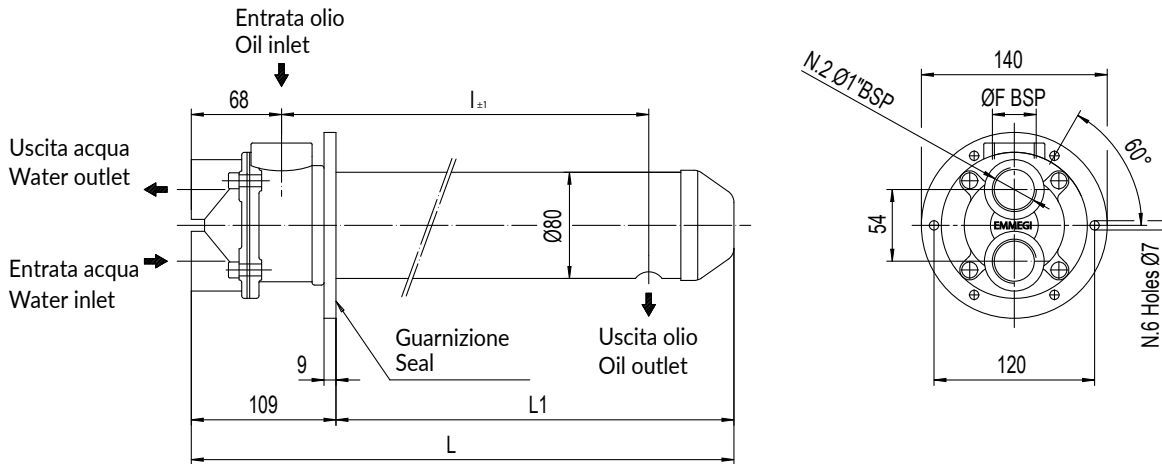

MG Water Series

MGF 80

Con circuito acqua ispezionabile a due passaggi. Two ways controllable water circuit



Le dimensioni e le caratteristiche non sono impegnative. Over-all dimension and technical characteristics are not binding.

TIPO TYPE	TUBI TUBES	PIASTRA TUBIERA TUBES SHEET	DEFLETTORI BAFFLES	FONDI COVERS	MANTELLO SHELL	GUARNIZIONI SEALS
STANDARD	CuDHP	CuZn40	CuZn37	CuZn40	CuZn37	Rubber-cork

TIPO TYPE	PORTATA OLIO OIL FLOW (lt/min)	HP DISSIPATI CON OLIO HP DISSIPATED WTK OIL =55°C H2O=20°C	CAPACITÀ CONTENTS (lt)	Kg	DIMENSIONI - Overall dimension 2 Pass			
					$\varnothing F$	I	L	L1
MGF 80-240-2	20-60	3-6	0.9	5	1"	240	369	260
MGF 80-340-2	30-70	6-9	1.2	5.7	1"	340	469	360
MGF 80-440-2	40-80	9-12	1.5	6.4	1"	440	569	460

DIAGRAMMA RENDIMENTO

Alla portata massima e minima indicata in tabella
PERFORMANCE DIAGRAM

At the maximum and minimum flow stated in schedule

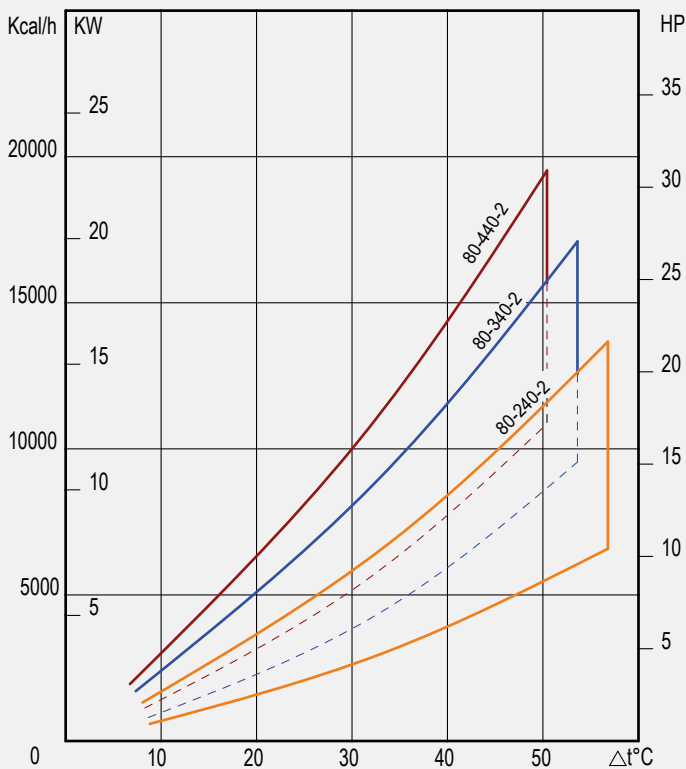

FATTORE DI CORREZIONE (F)-PERDITE DI CARICO CORRECTION FACTOR (F)-PRESSURE DROP

cst	10	15	20	30	40	50	60	80	100	200	300
F	0.5	0.65	0.77	1	1.2	1.4	1.6	1.9	2.1	3.3	4.3

PERDITE DI CARICA (32 cst) PRESSURE DROP (32 cst)

