

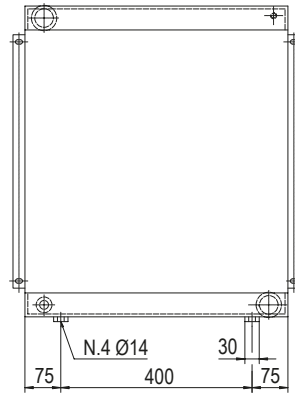

MG AIR

MG 2050K

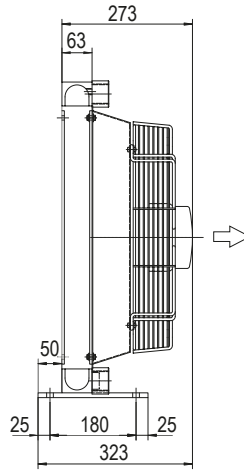
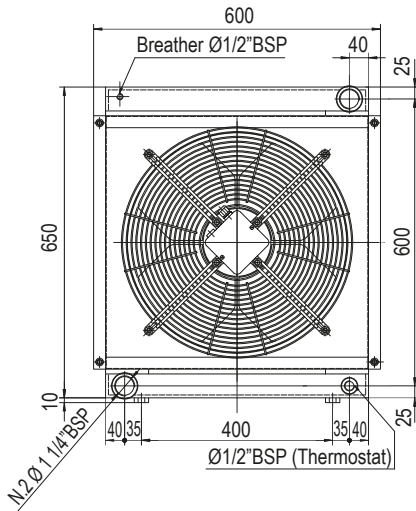

P/N 255003###

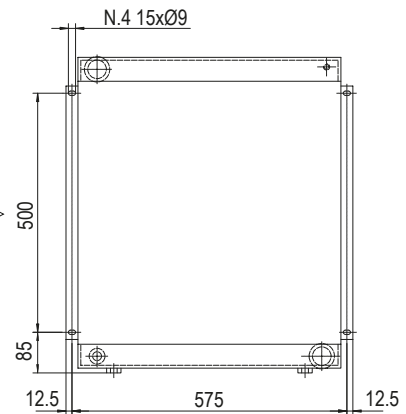
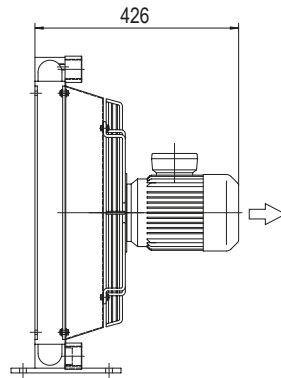
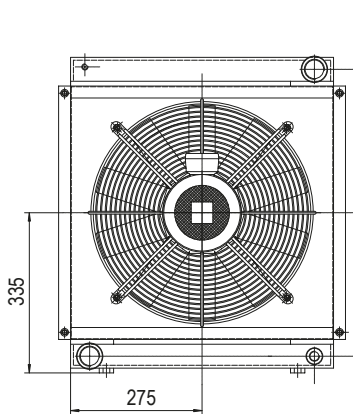

P/N 255004###

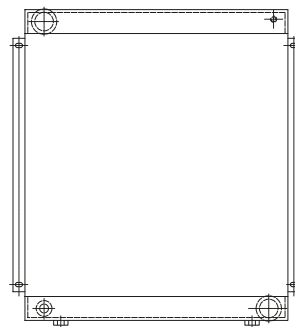
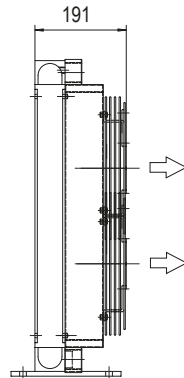
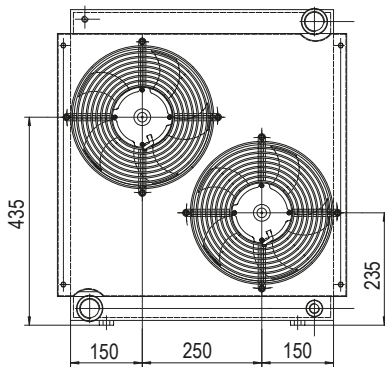

P/N 255012###
P/N 255024###

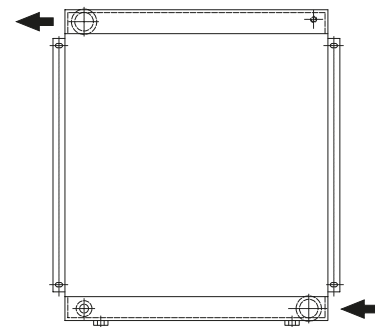
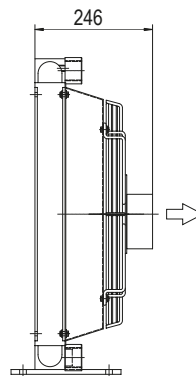
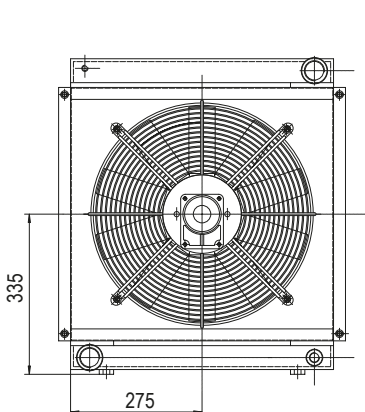

P/N 255056###

Le dimensioni di ingombro e le caratteristiche tecniche non sono impegnative
Over-all dimensions and technical characteristic are not binding



Dati tecnici Technical Data

P/N	V	Hz	kW(±10%)	A (±10%)	rpm	Ø Fan	dB (A)	(m³/ h)	IP	It	Kg
255003###	230-400 AC	50	0,52	1,9 - 1,1	1450	450	76	5000	54	5	27
	230-400 AC	60	0,66	2 - 1,2	1690						
255004###	230-400 AC B14	50	0,75	3,0-1,7	1440	450	79	5200	55	5	30
	230-400 AC B14	60	0,86	3,0-1,7	1750						
255012###	12 DC	/	0,13 (2x)	11,0 (2x)	2340 2600	280	76	1720 (2x)	68	5	24
255024###	24 DC	/	0,15 (2x)	6,2 (2x)	2600	280	79	1750 (2x)	68	5	24
252056###	Prepared for Gr.2 hydraulic motor					☎ 450	☎	☎	/	5	23

☎ Contattare EMMEGI Contact EMMEGI

Diagramma rendimento Performance diagram

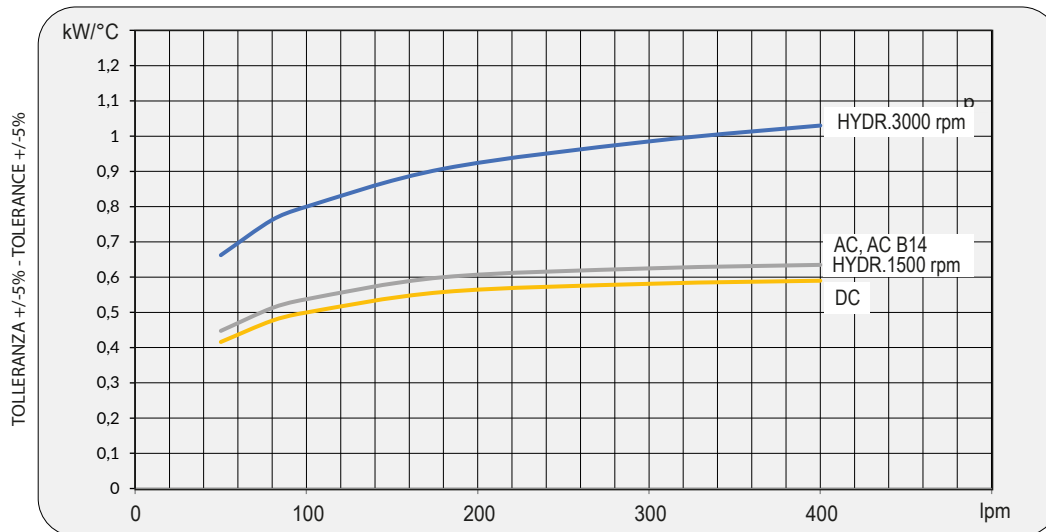

Perdite di carico Pressure drop (ISO VG 32)

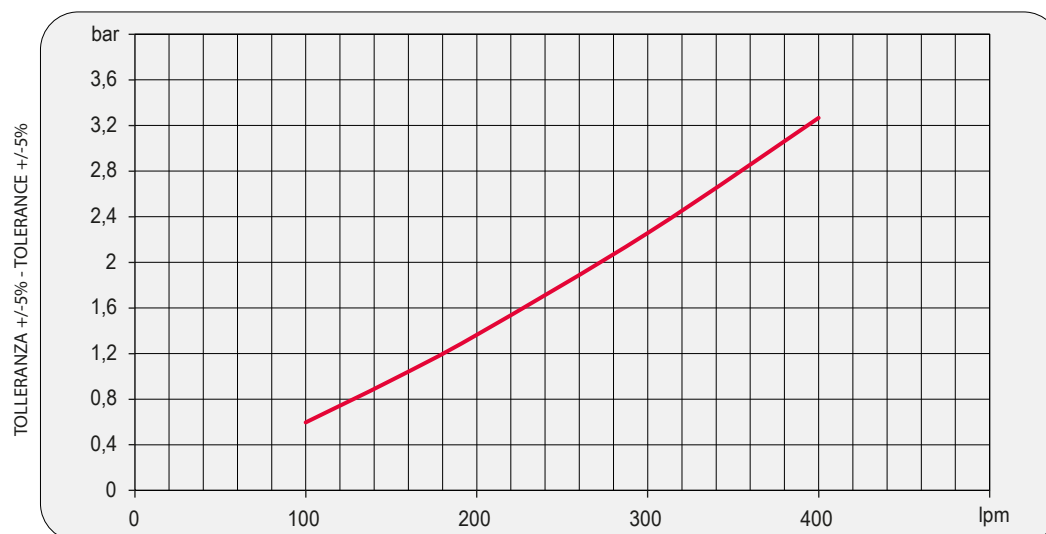

Fattore di correzione-F-(perdite di carico) Correction factor-F-(Pressure drop)

cst	10	15	20	30	40	50	60	80	100	200	300
F	0,5	0,65	0,77	1	1,2	1,4	1,6	1,9	2,1	3,3	4,3